

Cracking The Energy Codes

With a little
help from your
dedicated NBS
Energy Code
Decoders

Nucor
Building
Systems



Hello

Unfortunately, energy regulations are becoming increasingly complex and what it takes to meet them is constantly changing.

As the business contractor, it's your job to make sure you know, understand and meet all the compliance requirements and specifications at a price point that wins bids. That's why we've assembled a dedicated team of energy experts equipped with the knowledge and tools to help you meet the necessary energy codes in the most cost-effective manner possible.

Because at NBS we know energy codes.

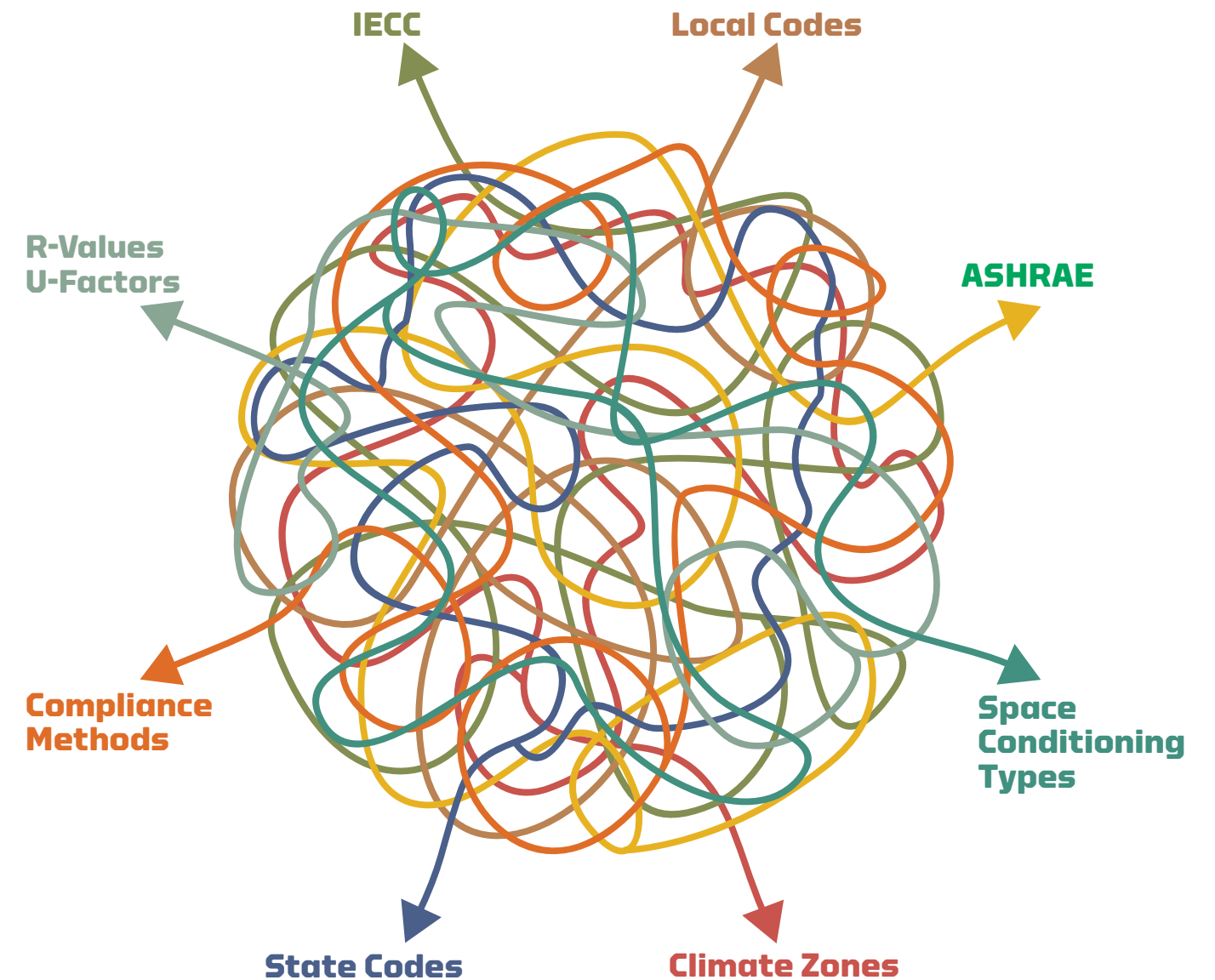

When it comes to energy, there are a variety of different regulating organizations, codes and requirements. This brochure will expand on those elements and help you better navigate the complex world of energy-compliant construction.

Energy Code Decoders

With so many codes and regulations on the state and local level that overlap and change on a regular basis, it's almost impossible to keep up and comprehend them all.

That's where we come in. We are your Energy Code Decoders and we're here to help. Our experienced and knowledgeable team knows energy compliance inside and out. From state codes to regional climate requirements and everything in between, we've got you covered.



Keeping things up to code

Meet the major players that influence your energy decisions.

International Energy Conservation Code (IECC)

The International Energy Conservation Code is a model code that regulates minimum energy conservation requirements for new buildings. The IECC references ASHRAE 90.1 in addressing energy conservation requirements for all aspects of energy uses in both commercial and residential construction – including heating and ventilating, lighting, water heating, and power usage for applications and building systems. Our team is well versed in IECC regulations and our products make it easy for you to comply with even the most stringent of codes.

American Society of Heating, Refrigeration and Air-Conditioning Engineers (ASHRAE)

ASHRAE 90.1 provides the minimum requirements for energy-efficient design of most buildings except low-rise residential buildings. It offers in detail the minimum energy-efficient requirements for design and construction of new buildings and their systems, new portions of buildings and their systems, and new systems and equipment in existing buildings, as well as criteria for determining compliance with these requirements. It is an indispensable reference for engineers and other professionals involved in the design of buildings and building systems. While some ASHRAE 90.1 standards can be stringent and continuously changing, our experienced staff and specially designed products can help you stay up to code.

Both IECC and ASHRAE 90.1 are updated every three years and adopted by states and/or local municipalities.

R-Value vs. U-Factor

Knowing what R-value and U-factor mean is key to decoding energy issues and to selecting products that best suit the climate zone you are building in. R-value is essentially a product's resistance to heat flow, which means that the higher the product's R-value, the better it is at insulating a building and improving energy efficiency. Conversely, U-factor measures the rate of heat transfer. This means that products with a lower U-factor will be more energy efficient.

$$R=1/U \text{ \& } U=1/R$$

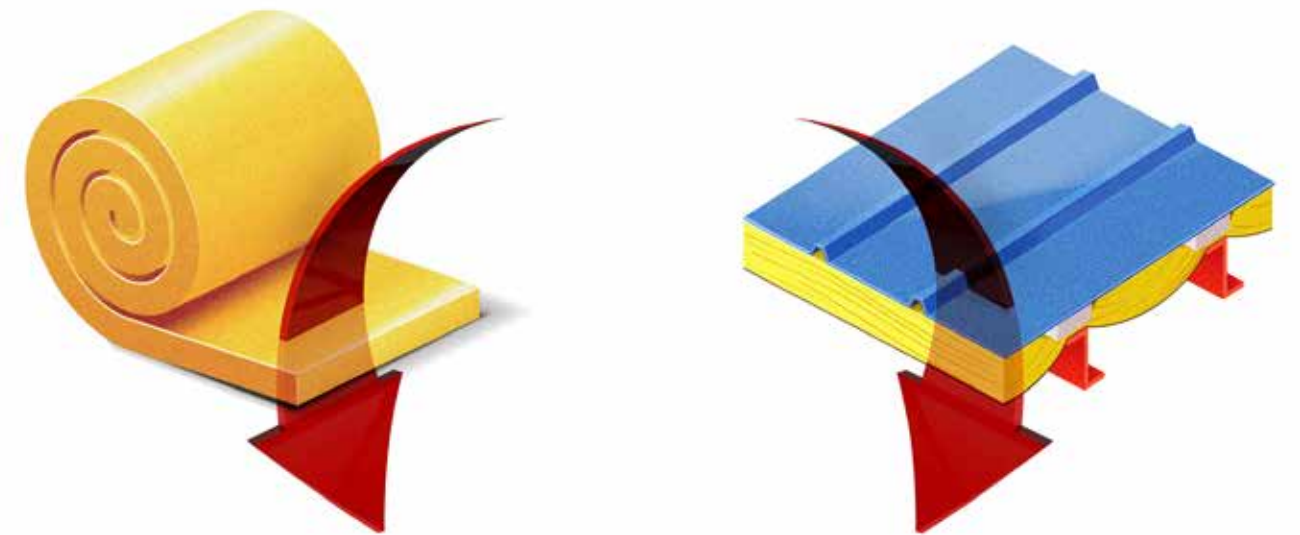

What is R-value?

R-value tells us how well a particular construction material insulates. The higher the R-value, the better the insulation and the more energy you will save. An R-value only applies to specific materials, not to systems.

What is U-factor?

U-factor is generally used to rate systems like an insulated wall or roof panel. The lower the U-factor, the more energy efficient the system in question will be. A U-factor is typically a low number because it is a rating of how much heat energy is lost or gained.

State/Local Codes

Most states have their own energy codes, which are often modeled after the IECC or ASHRAE 90.1 energy standards. Some states choose to have no guiding codes or regulations at all, while others require older versions of the IECC or ASHRAE. But more and more states are choosing to update their regulations and adhere to newer, more rigorous codes. The more recent the year of the standard they model their codes after, the stricter, more energy efficient the requirements are. In states where no codes are in place, some cities may still have codes that you need to follow. It is important to check the local regulations and requirements before beginning a construction project.

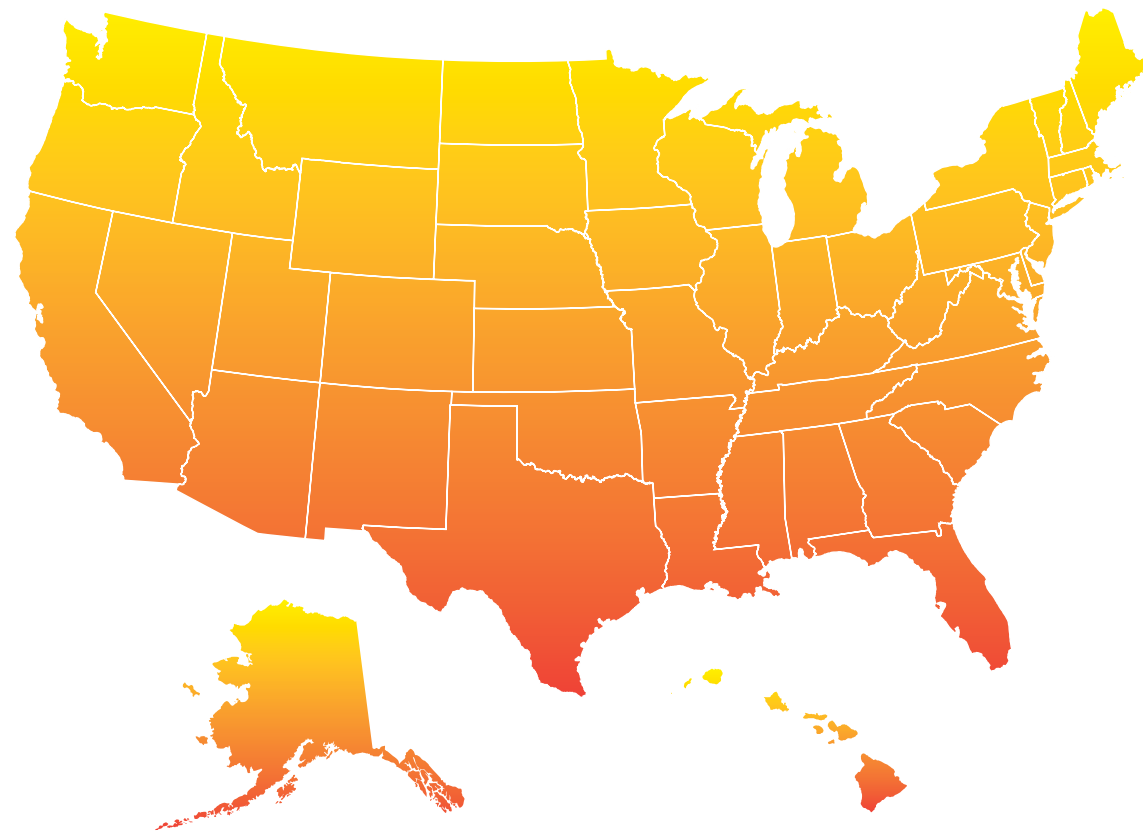

Climate Zones

The state and local codes include energy requirements for whatever climate zone they are in. There are 8 different climate zones in total, each with its own energy requirements. Since many states have multiple climate zones within their borders, it is crucial that you know the climate zone requirements for each part of the state.

ZONE 1 **ZONE 2** **ZONE 3** **ZONE 4** **ZONE 5** **ZONE 6** **ZONE 7** **ZONE 8**

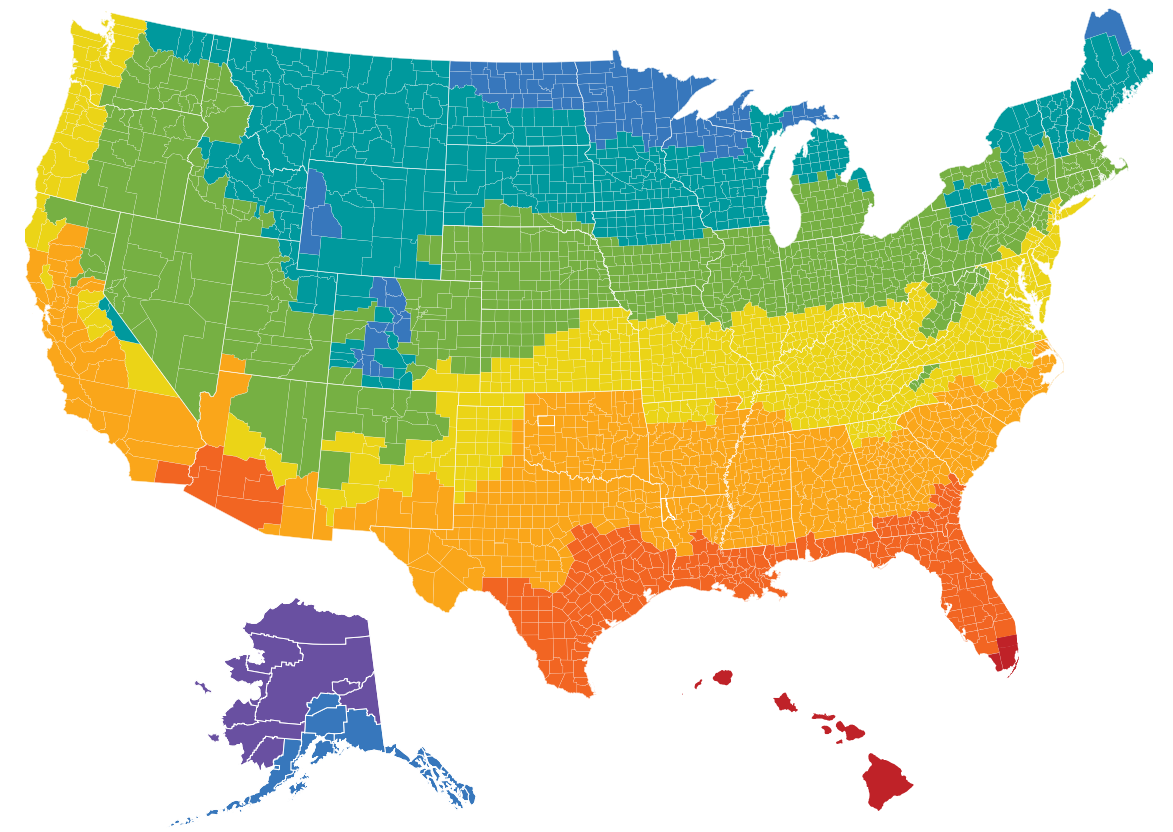

Insulation Terminology

We highlight key terms and definitions listed in the aforementioned energy codes for roof and wall insulation assemblies in regard to metal buildings.

The energy guidelines such as IECC and ASHRAE can often times be challenging to grasp, with wording that can get difficult and confusing. So we've compiled a list of some of the key terms you need to know when trying to make your building code compliant.

Single Layer

A standing seam roof with a single layer of faced fiberglass insulation batts draped perpendicular over the purlins. A thermal spacer block is placed above the batt, with the roof deck secured to the purlins.

Double Layer

A standing seam roof with two layers of fiberglass insulation. Double layer roofs contain two R-values – the first comes from the faced fiberglass insulation batts draped over the purlins. The second R-value correlates to the unfaced fiberglass insulation batts installed parallel to the purlins.

Filled Cavity

A standing seam roof with filled cavity fiberglass insulation. This assembly also has two R-values. The first R-value comes from the faced or unfaced insulation that is installed between the purlins. The second R-value is for the unfaced insulation installed above the first layer, perpendicular to the purlins and compressed when the metal roof panels are attached. A supporting structure retains the bottom of the first layer at the prescribed depth required for the full thickness of insulation.

Liner System

A standing seam roof with liner system fiberglass insulation with a continuous membrane is installed below the purlins and uninterrupted by framing members. Uncompressed, unfaced insulation rests on top of the membrane between the purlins.

Continuous Insulation

Assembly method where insulation is installed above or below the purlins, uncompressed and uninterrupted by framing members.

Methods to Compliance

Energy codes include mandatory requirements, along with various compliance methods that you can choose from based on your specific needs.

The mandatory requirements must be met in every building design no matter which compliance option is chosen. The three main compliance options are the Prescriptive Method, Building Envelope Trade-Off Method and Energy Cost Budget Method.

Prescriptive Building Method

The Prescriptive Building option is the easiest method to comply with, but it's not always the most cost effective. With this option, there is no need to know what mechanical systems or lighting is going to be used. The Prescriptive Method doesn't allow for trade-offs, and the requirements may have to be exceeded in some cases due to whatever products or assemblies are available to you.

Building Envelope Trade-Off Method

The Building Envelope Trade-Off option provides much greater flexibility than the Prescriptive Method. It allows the use of certain components that, by themselves, may not meet the Prescriptive requirements. But, this method allows for trade-offs in the form of roof with walls, walls with roof, windows, doors, slab insulation, etc. in order to meet your specific requirements.

Energy Cost Budget Method

The Energy Cost Budget option is the only method that provides the theoretical expected energy consumption of a proposed building versus a building that satisfies the minimum requirements. It's also the only method that allows for trade-offs between mechanical and lighting systems and the building envelope. This is the most complex method and will almost always require an energy consultant to be retained to compare and contrast all of the various scenarios. Spray foam can also be used as a means of insulation with this option.



Space Conditioning Types

According to ASHRAE, any area enclosed within a building is considered a space.

Commercial space conditioning accounts for about 7.0 quads of primary energy per year, or about 40% of total commercial energy use in the United States.

There are three basic types of space conditioning defined by ASHRAE and IECC, and each one requires different energy codes.

Conditioned Space

IECC defines a conditioned space as an area, room or space that is enclosed within the building thermal envelope and is directly or indirectly heated or cooled. Spaces are indirectly heated or cooled where they communicate through openings with conditioned spaces; where they are separated from conditioned spaces by uninsulated walls, floors or ceilings; or where they contain uninsulated ducts, piping or other sources of heating or cooling.

ASHRAE 90.1 defines a conditioned space as a cooled space, heated space or indirectly conditioned space. Cooled, heated and indirectly conditioned spaces are defined as follows:

Cooled space – an enclosed space within a building that is cooled by a cooling system whose sensible output capacity exceeds 5 Btu/h-ft² of floor area.

Heated Space – an enclosed space within a building that is heated by a heating system whose output capacity relative to the floor area is greater than or equal to the minimum heating output for its climate zone.

Indirectly Conditioned Space – an enclosed space within a building that is not a heated space or a cooled space, which is heated or cooled indirectly by being connected to adjacent conditioned and/or semiheated spaces.

Semiheated Space

A semiheated space only applies to ASHRAE 90.1, not IECC. ASHRAE 90.1 states that a heated space is an enclosed space within a building that is heated by a heating system whose output capacity is greater than or equal to 3.4 Btu/h-ft² of floor area but is not a conditioned space.

Unconditioned Space

An unconditioned space is an enclosed space within a building that is not a conditioned space or a semiheated space. Crawlspace, attics and parking garages with natural or mechanical ventilation are not considered enclosed spaces.

Our Solutions

At NBS, we have a multitude of energy solutions to help you adhere to even the strictest codes. From apps and software to revolutionary products and comprehensive knowledge - when it comes to meeting code, you can count on us.

Cool Coating

Lower your energy costs and make your buildings stand out with our vibrant line of cool coatings. All of our wall and roof panels are available with our silicone polyester or PVDF cool coating finishes. Vivid color. Eco-efficiency. Low-maintenance reliability.

Daylighting

Daylighting with Prismatic Skylights is the controlled admission of natural sunlight into your building using diffused skylights in conjunction with energy-efficient lighting and a daylight-responsive lighting control system – helping you get up to code and maximizing your energy savings. Daylighting significantly reduces the need for electric light, which significantly cuts down on energy costs.

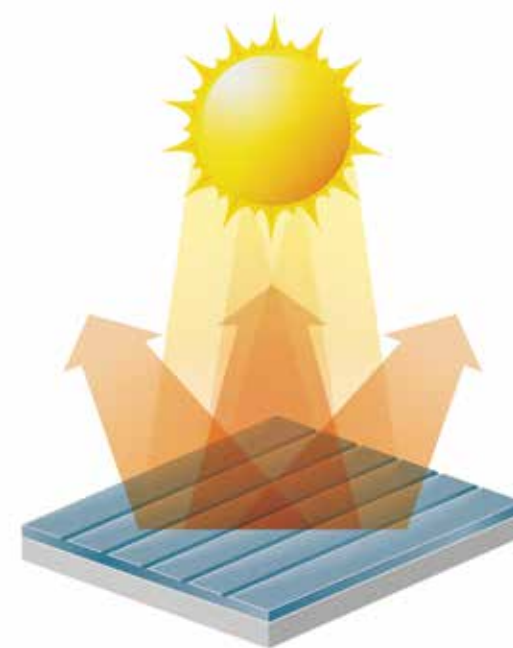

Using cool wall and roof panels can help you meet energy codes.

To be considered cool, products must have a solar reflectance of at least 25%. Another important factor is thermal emittance. Put these two factors together and you get the solar reflectance index – which is the measure of a panel's ability to reflect solar heat.



Advanced Prismatic Skylight

Our modern prismatic skylights transmit more light than conventional skylights while diffusing 100% of incoming rays. For many institutional and commercial buildings, strategic daylighting can reduce total energy costs by as much as one-third.

Insulated Metal Panels

Our insulated wall and roof panels are the ultimate in energy efficiency.

These patented panels make your buildings easier to cool in hot summer months and keep out the cold air in more frigid climates.

Insulated Wall Panels

Our patented wall panels come in three different variations: Striated Profile, Double Mesa Profile and Heavy Embossed Profile. You can choose from 4 different thickness levels, with the required R-value increasing with thickness and U-factor decreasing with thickness.



Striated Profile (ST40)



Double Mesa Profile (DM40)



Heavy Embossed Profile (HE40)

Thickness	2"	2.5"	3"	4"
R-Values	R16	R20	R24	R32
U-Factors	0.061	0.049	0.041	0.031
Width	40"	40"	40"	40"

Insulated Roof Panels (SR2)

These mechanically seamed roof panels are an ideal solution where energy-efficient standing seam roof panels are required. The unique design of this panel allows for 26-gauge exterior and interior skins, saving money and weight on a building.



Thickness	2.5"(HR3)	3.25"(SR2)	4"	5"	6"
R-Values	R21	R26	R33	R42	R50
U-Factors	0.05	0.038	0.031	0.024	0.020
Width	40"	40"	40"	40"	40"

The Right Tools For the Job

You'll have a toolbox full of energizing solutions right at your fingertips with NBS's Toolbox App.

eQuote

eQuote is a proprietary, industry-leading pricing system designed to provide the most accurate, detailed scope documents to successfully and efficiently quote projects.

Nucor Steel Store

The Nucor Steel Store is the single largest source of custom steel construction products available for purchase online.

Product Bulletins

Never miss an important product change or update with access to our product bulletin portal.

Builders Resources

The most convenient way to access the Builders Resources information you need – all in one place!

Message Center

Stay up to date when you're on the go with easy access to the latest news and announcements.

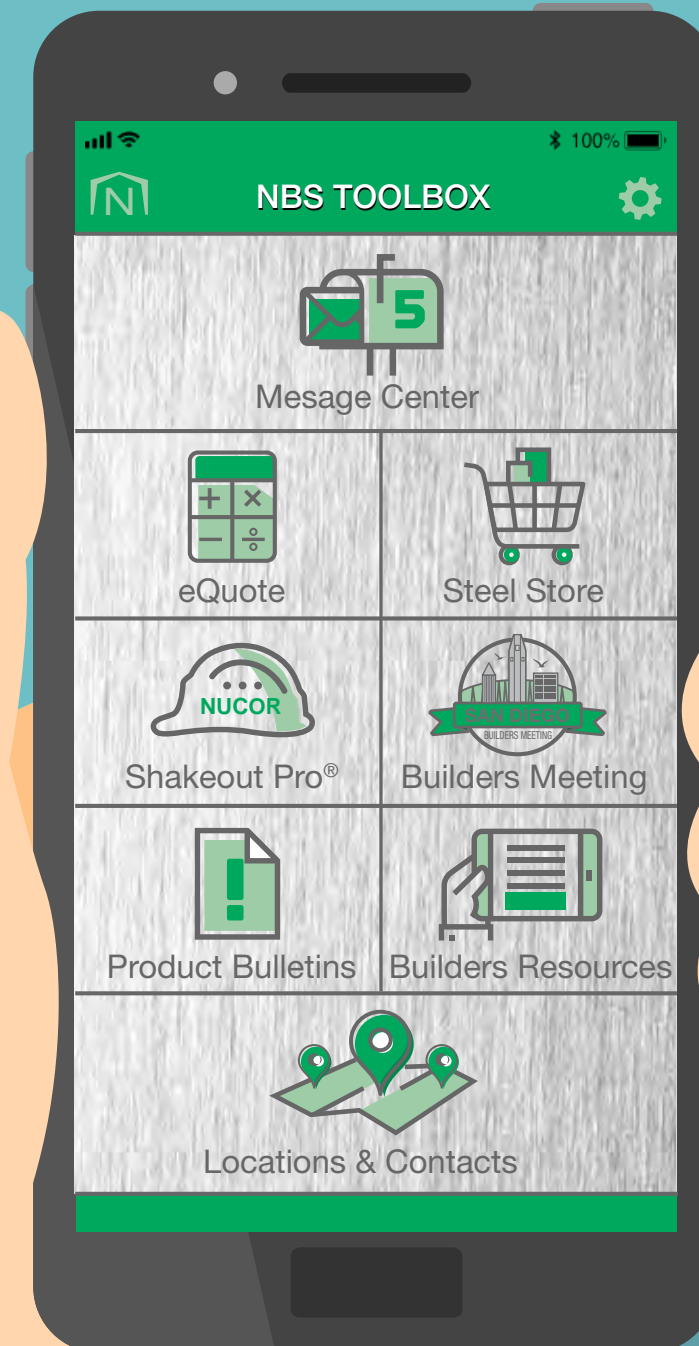

Check it with COMcheck™

COMcheck™ is an incredibly useful tool to help you become energy compliant.

Just type in the necessary building information and COMcheck™ will determine whether or not you are compliant with your specific energy code, as well as help you decide what needs to be changed in order to become compliant.

COMcheck™ lets you run your building using assemblies of different performances, giving you the ability to select the most cost-effective options to become code compliant. Our team can even help provide COMcheck™ files for you. From IECC and ASHRAE to local and state codes, always be sure to double-check with COMcheck™.

COMcheck

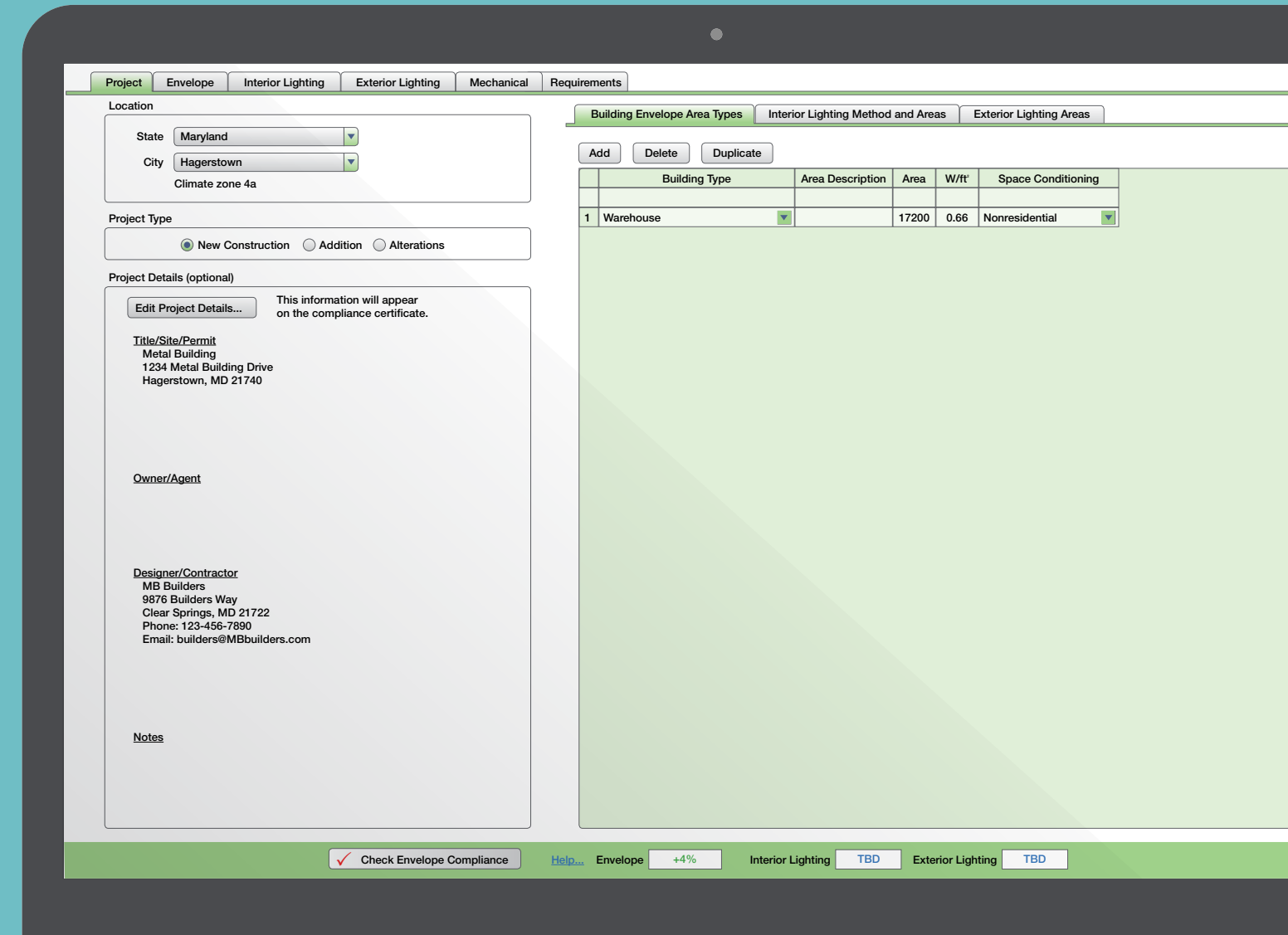

Insulated Roof Systems

Our insulated roof systems will help keep you energy compliant in any climate, season after season after season.

Liner System Standing Seam Roof w/TB (3 layers)

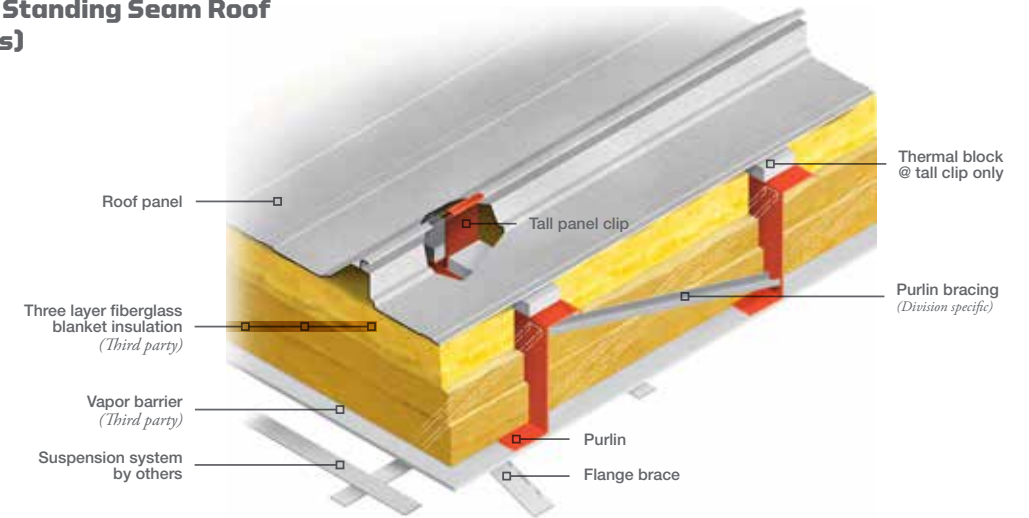

Liner System Standing Seam Roof w/TB (2 layers)

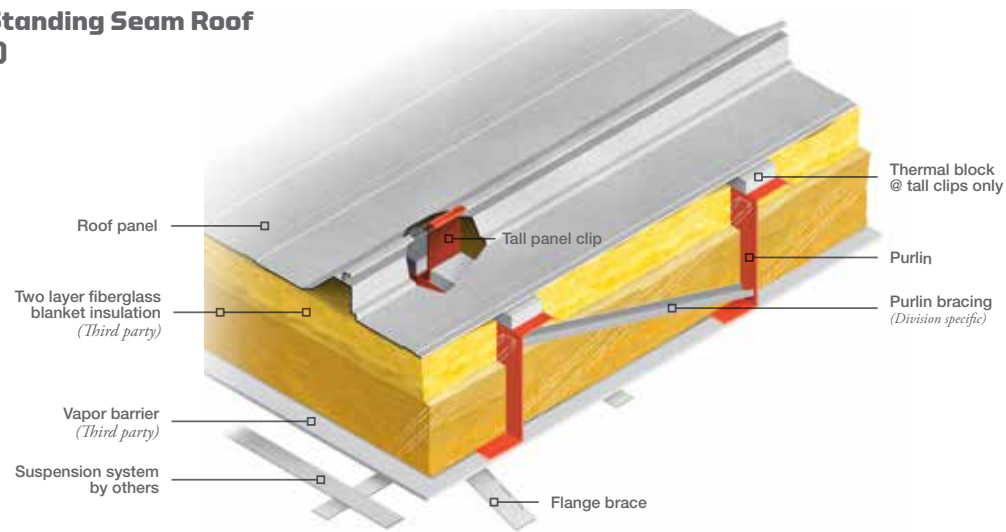

Single Layer Standing Seam Roof w/TB

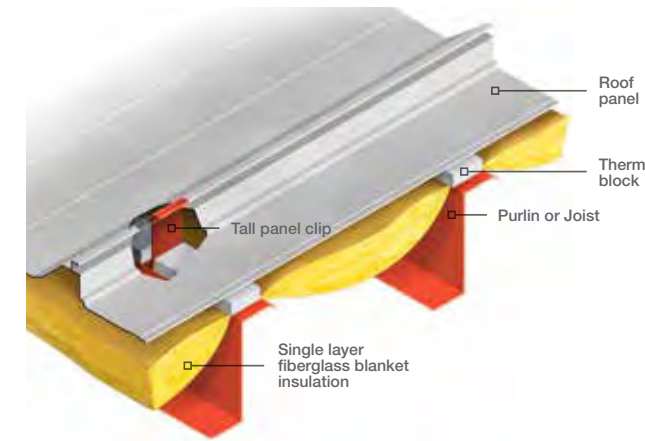

Double Layer Standing Seam Roof w/TB

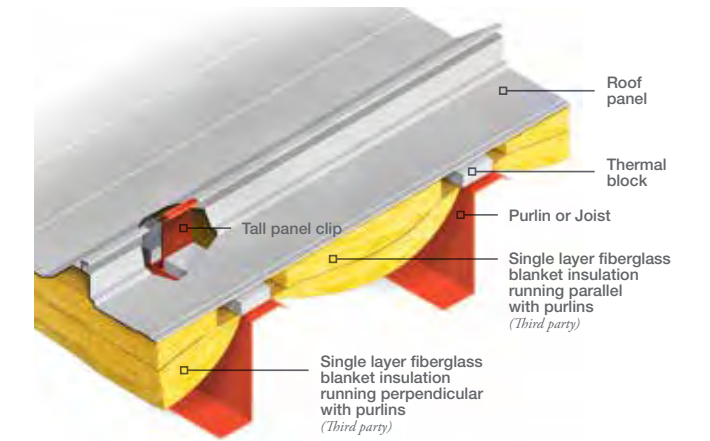

Long Tab Banded Liner System w/TB (2 layers)

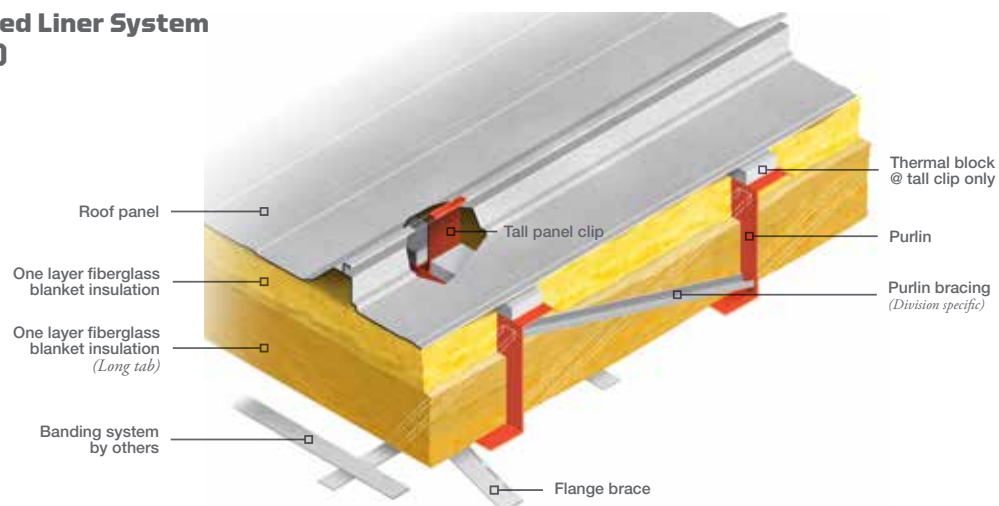

Insulated Metal Panel

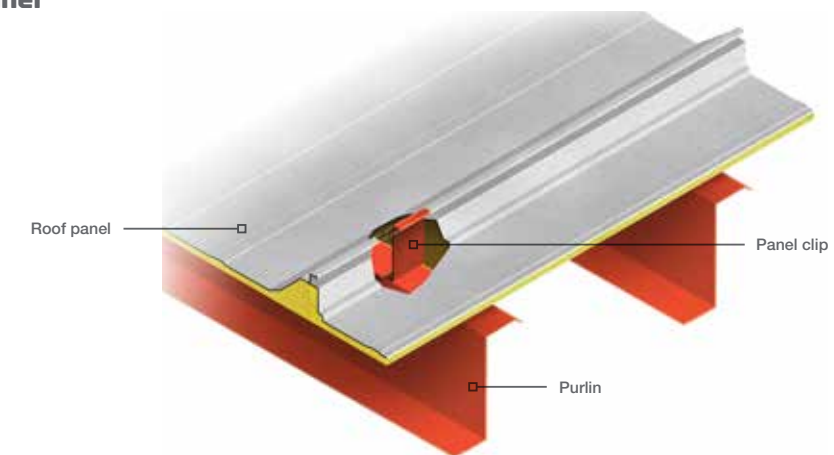

Insulated Wall Systems

The ultimate in energy efficiency. Our insulated wall systems can keep you up to code in the heat or the cold.

Double Layer Wall

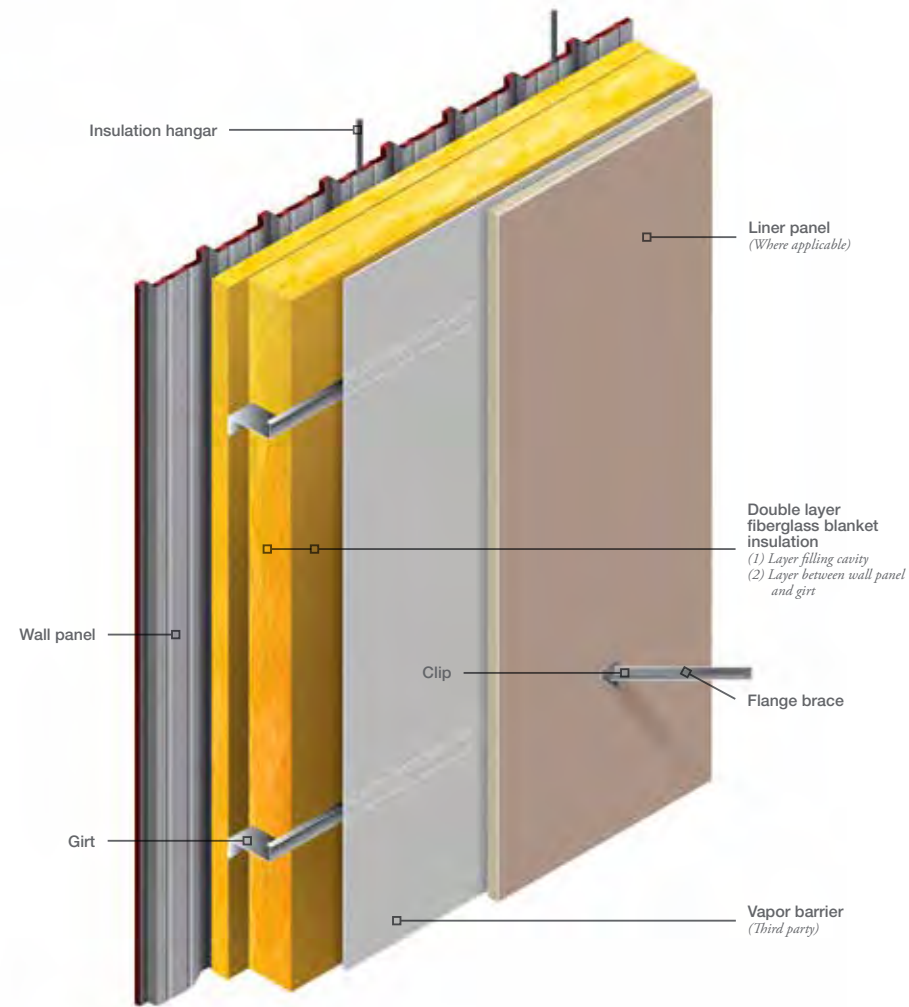

Double Layer Wall w/TB

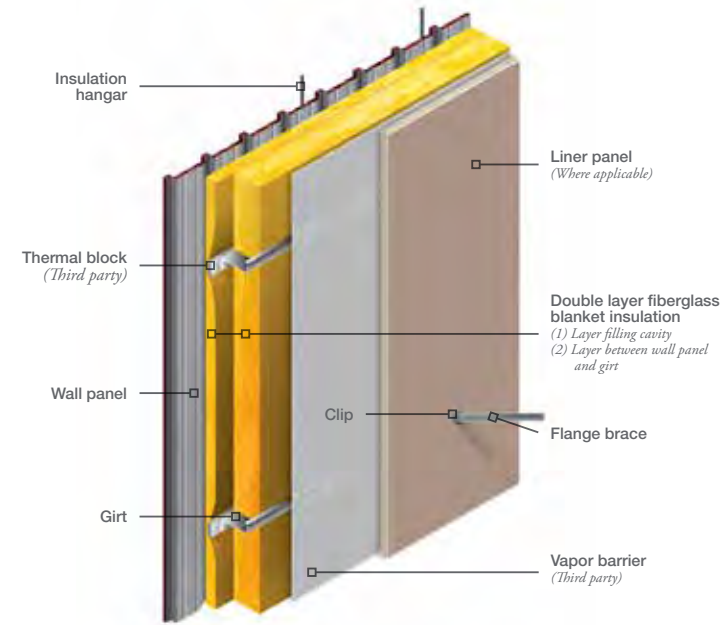

Single Layer in Cavity Wall w/TB

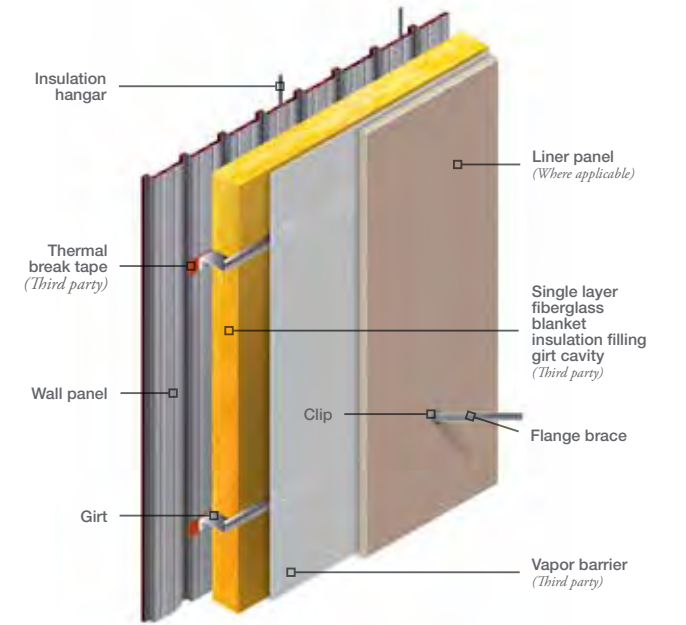

Single Layer in Wall

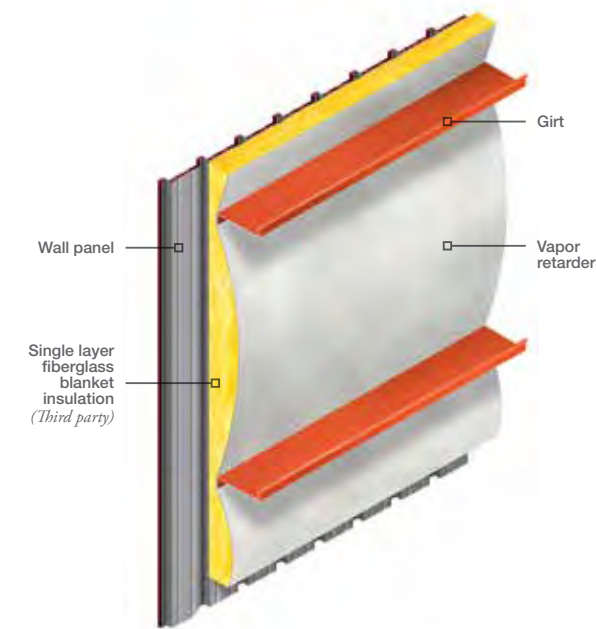

Insulated Metal Panel

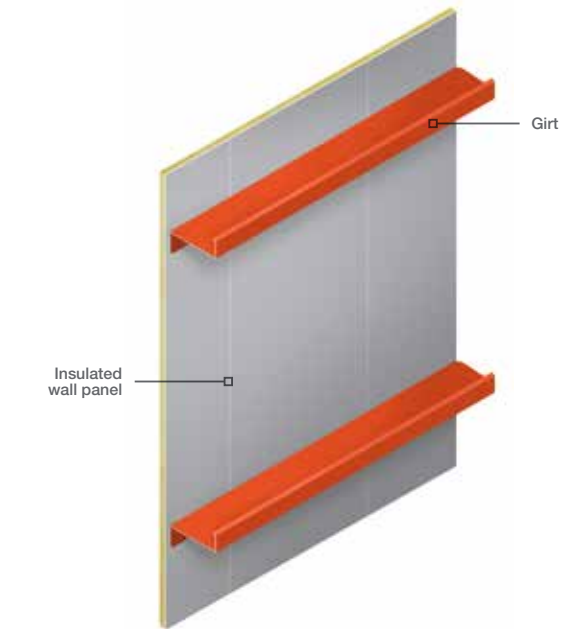

Envelope Energy Codes

Use our comprehensive energy code charts to ensure you're always up to code, no matter the building, no matter the climate.

Envelope Energy Codes - U.S.

Metal Buildings Conditioned Space - ASHRAE 90.1

ASHRAE 90.1 2010	Zone 1	Zone 2	Zone 3	Zone 4	Zone 5	Zone 6	Zone 7	Zone 8
Roof - U-factors	0.065	0.055	0.055	0.055	0.055	0.049	0.049	0.035
Prescriptive Compliance								
Fiberglass	R19	R25* CFR	R25* CFR	R25* CFR	R25* CFR	R30* CFR	R30* CFR	R11+R19 LS
Insulated Metal Panels	2.5"	2.5"	2.5"	2.5"	2.5"	3.25"	3.25"	4"
Wall - U-factors	0.093	0.093	0.084	0.084	0.069	0.069	0.057	0.057
Prescriptive Compliance								
Fiberglass	R16	R16	R19	R19	R25* w/TB	R25* w/TB	R30* w/TB	R30* w/TB
Insulated Metal Panels	2"	2"	2"	2"	2"	2"	2.5"	2.5"

ASHRAE 90.1 2013	Zone 1	Zone 2	Zone 3	Zone 4	Zone 5	Zone 6	Zone 7	Zone 8
Roof - U-factors	0.041	0.041	0.041	0.037	0.037	0.031	0.029	0.026
Prescriptive Compliance								
Fiberglass	R10+R19 FC	R10+R19 FC	R10+R19 FC	R19+R11 LS	R19+R11 LS	R25+R11 LS	R30+R11 LS	R25+R11+R11 LS
Insulated Metal Panels	3.25"	3.25"	3.25"	4"	4"	4"	5"	5"
Wall - U-factors	0.094	0.094	0.094	0.060	0.050	0.050	0.044	0.039
Prescriptive Compliance								
Fiberglass	R19* RR/V	R19* RR/V	R19* RR/V	R25* w/TB	R25+R10	R25+R10	R25+R16	R25+R10* w/TB
Insulated Metal Panels	2"	2"	2"	2.5"	2.5"	2.5"	3"	3.25"

- FC Filled Cavity
- LS Liner System
- TB Thermal Break
- RR/V Reverse Roll, Accent Panel, or V-rib panels are required to achieve the performance indicated.
- CFR Nucor CFR is required to achieve the performance indicated.
 - a "Single Layer in Cavity" A minimum R-0.375 thermal spacer block or thermal break strip is required when installed without continuous insulation.
 - b "Single Layer in Cavity" A minimum R-0.75 thermal spacer block or thermal break strip is required.
 - c "Double Layer" A minimum R-3 thermal spacer block is required when installed without continuous insulation.
 - * The system performance has been validated through the use of either hot box testing or finite element modeling.

Envelope Energy Codes - U.S.

Metal Buildings Semiheated Space - ASHRAE 90.1

ASHRAE 90.1 2010	Zone 1	Zone 2	Zone 3	Zone 4	Zone 5	Zone 6	Zone 7	Zone 8
Roof - U-factors	0.167	0.097	0.097	0.097	0.083	0.072	0.072	0.065
Prescriptive Compliance								
Fiberglass	R6	R10	R10	R10	R13	R16	R16	R19
Insulated Metal Panels	2.5"	2.5"	2.5"	2.5"	2.5"	2.5"	2.5"	2.5"
Wall - U-factors	0.113	0.113	0.113	0.113	0.113	0.113	0.113	0.113
Prescriptive Compliance								
Fiberglass	R13	R13	R13	R13	R13	R13	R13	R13
Insulated Metal Panels	2"	2"	2"	2"	2"	2"	2"	2"

ASHRAE 90.1 2013	Zone 1	Zone 2	Zone 3	Zone 4	Zone 5	Zone 6	Zone 7	Zone 8
Roof - U-factors	0.115	0.096	0.096	0.082	0.082	0.060	0.037	0.037
Prescriptive Compliance								
Fiberglass	R10	R16	R16	R19	R19	R25* CFR	R19+R11 LS	R19+R11 LS
Insulated Metal Panels	2.5"	2.5"	2.5"	2.5"	2.5"	2.5"	4"	4"
Wall - U-factors	0.352	0.0162	0.0162	0.0162	0.094	0.094	0.072	0.060
Prescriptive Compliance								
Fiberglass	NR	R13	R13	R13	R19* RR/V	R19* RR/V	R25 ^a w/TB	R25 ^a w/TB
Insulated Metal Panels	2"	2"	2"	2"	2"	2"	2"	2.5"

Metal Buildings Conditioned Space - IECC

IECC 2012	Zone 1	Zone 2	Zone 3	Zone 4	Zone 5	Zone 6	Zone 7	Zone 8
Roof - U-factors	0.044	0.035	0.035	0.035	0.035	0.031	0.029	0.029
Prescriptive Compliance								
Fiberglass	R19+R11 LS	R19+R11 LS	R19+R11 LS	R19+R11 LS	R19+R11 LS	R25+R11 LS	R30+R11 LS	R30+R11 LS
Insulated Metal Panels	3.25"	4"	4"	4"	4"	4"	5"	5"
Wall - U-factors	0.079	0.079	0.079	0.052	0.052	0.052	0.052	0.052
Prescriptive Compliance								
Fiberglass	R25* w/TB	R25* w/TB	R25* w/TB	R30* w/TB	R30* w/TB	R30* w/TB	R30* w/TB	R30* w/TB
Insulated Metal Panels	2"	2"	2"	2.5"	2.5"	2.5"	2.5"	2.5"

IECC 2015	Zone 1	Zone 2	Zone 3	Zone 4	Zone 5	Zone 6	Zone 7	Zone 8
Roof - U-factors	0.044	0.035	0.035	0.035	0.035	0.031	0.029	0.029
Prescriptive Compliance								
Fiberglass	R19+R11 LS	R19+R11 LS	R19+R11 LS	R19+R11 LS	R19+R11 LS	R25+R11 LS	R30+R11 LS	R30+R11 LS
Insulated Metal Panels	3.25"	4"	4"	4"	4"	4"	5"	5"
Wall - U-factors	0.079	0.079	0.079	0.052	0.052	0.052	0.052	0.052
Prescriptive Compliance								
Fiberglass	R25* w/TB	R25* w/TB	R25* w/TB	R30* w/TB	R30* w/TB	R30* w/TB	R30* w/TB	R30* w/TB
Insulated Metal Panels	2"	2"	2"	2.5"	2.5"	2.5"	2.5"	2.5"

- LS Liner System
- TB Thermal Break
- RR/V Reverse Roll, Accent Panel, or V-rib panels are required to achieve the performance indicated.
- CFR Nucor CFR is required to achieve the performance indicated.
 - a "Single Layer in Cavity" A minimum R-0.375 thermal spacer block or thermal break strip is required when installed without continuous insulation.
 - b "Single Layer in Cavity" A minimum R-0.75 thermal spacer block or thermal break strip is required.
 - c "Double Layer" A minimum R-3 thermal spacer block is required when installed without continuous insulation.
 - * The system performance has been validated through the use of either hot box testing or finite element modeling.
- NR no (insulation) requirement.

Meet Codes and Win Bids

The energy experts at NBS have the products, experience and know-how needed to help you meet codes and exceed expectations in any climate.

Contact us today and let's get started.



1.844.682.6724



nbg.energy@nucor.com

Nucor Building Systems

NUCOR BUILDING SYSTEMS

INDIANA

305 Industrial Parkway
Waterloo, IN 46793
260.837.7891

SOUTH CAROLINA

200 Whetstone Road
Swansea, SC 29160
803.568.2100

TEXAS

600 Apache Trail
Terrell, TX 75160
972.524.5407

UTAH

1050 N. Watery Lane
Brigham City, UT 84302
435.919.3100

